

Hy-Lok RP Series

Rising Plug Valves



Catalog No. H-RP100
Feb. 2015

Robust Bar Handle

- sintered stainless steel handle.

Stem Thread

- is to prevent particle build-up and for long life.
- is above the packing to prevent fluid contamination.

Bonnet Loking Pin

- ensures no disassembly.

Variety of End Connections

- include male/female NPT and Male/Female ISO/BSP Female Hy-Lok Tube Fittings.

POM Cone Seat

- is standard for easier replacement and PEEK is also available as option.

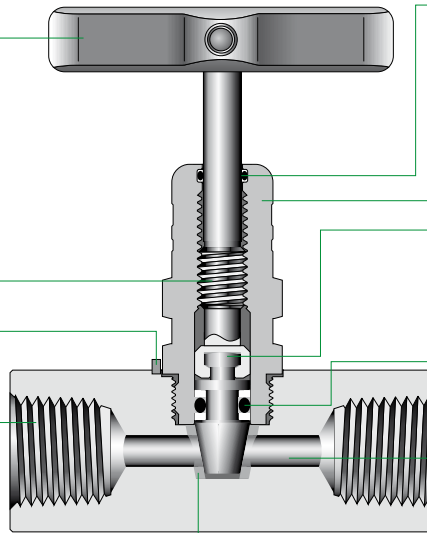

Internal Seal

- prevent ingress of foreign materials into the actuating threads.

Panel Mount

- is available as option.

Non-Rotating Stem Tip

- ensures positive sealing minimizing seat wear-out.

FKM O-Ring with Back-up Ring

- is standard.

Orifice in Straight Flow Path

- ensures max Cv.

Features

- **Pressure rating**
up to 6000 psig at 100 °F (38 °C)
- **Gauge port** available as option
- **SS316 body** as standard
- **Sour gas service** available.
- **100% factory tested**

Materials of Construction

Description	Material / ASTM Specification
Body	SS316 / A479 or A276
Bonnet	
Stem	
Tip	
Seat	POM Standard
Seal	FKM Standard
Handle Set	Stainless Steel
Locking Plate	Stainless Steel

Temperature and Pressure Ratings

Seat Materials	Temperature Rating	Pressure Rating @ 100 °F (38 °C)	Pressure Rating @ Max Temperature
POM (standard)	-20 °F ~ 250 °F (-29 °C ~ 121 °C)	6,000 psig (413 bar)	1,000 psig @ 250 °F (121 °C)
PEEK (optional)	-20 °F ~ 400 °F (-29 °C ~ 204 °C)	6,000 psig (413 bar)	1,000 psig @ 250 °F (121 °C)

Spare Seat

available for maintenance as below

Part No.	Seat Materials	Q'ty / Pack
RPV - * - DS	POM Seat	1 pc
RPV - * - PK	PEEK Seat	1 pc

- **Note *** : for end connection and size designator e.g. RPV-MF8N-PK (See Ordering Information)



HY-LOK CORPORATION

© 1998, 1999, 2002, 2015 HY-LOK CORPORATION All rights reserved

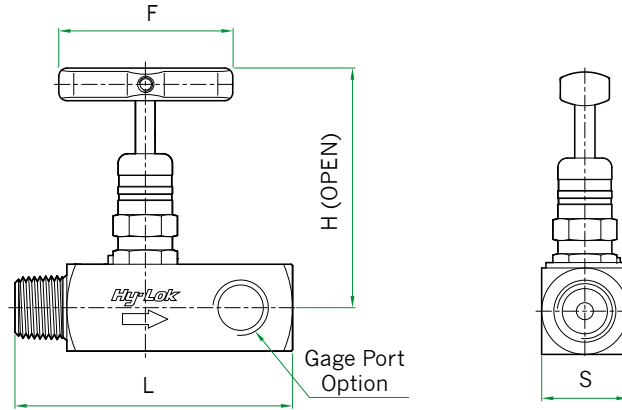
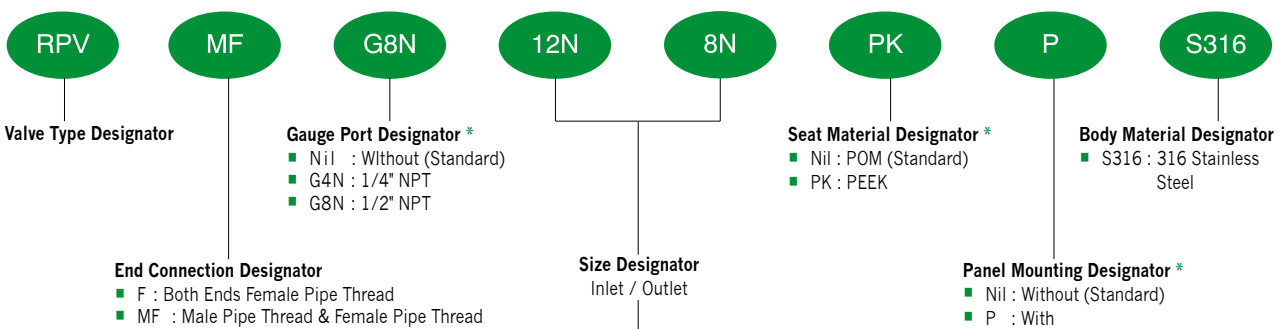

Table of Dimensions

Basic Part No.	Orifice Hole	Cv	End Connections		Dimensions				
			Inlet	Outlet	L	S	F	H	
RPV	F -4N	6.3 (0.25)	1.77	1/4" Female NPT		62.0 (2.44)	25.4 (1.00)	60 (2.36)	95.4 (3.75)
	MF -4N			1/4" Male NPT	1/4" Female NPT	74.0 (2.91)			
	F -8N			1/2" Female NPT		84.0 (3.31)	32.0 (1.26)		97.5 (3.34)
	MF -8N			1/2" Male NPT	1/2" Female NPT	90.0 (3.54)			
	MF -12N8N			3/4" Male NPT	1/2" Female NPT				

All dimensions in millimeters.

Ordering Information



NPT (ISO/BSP)

Thread (in.)	1 / 4	1 / 2	3 / 4
Designator	4N (R)	8N (R)	12N (R)

Note * : No designator is required for standard.
e.g. RPV MF-12N 8N-S316

SAFETY in VALVE SELECTION

Proper installation, materials compatibility, operation and maintenance of these valves are the responsibility of the user. The total system design must be taken into consideration to ensure optimal performance and safety.