

Hy-Lok FI Series

Micron Inline Filter

Catalog No. H-F200
Mar. 2004

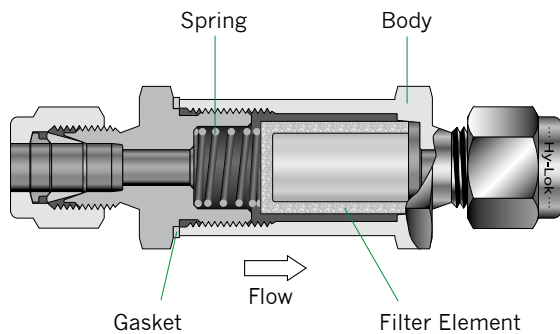

Features

- In-line filters are for use where space is limited
- Replaceable Filter element
- Particle trapping for clean fluid

Material of Construction

Description	Material / ASTM Specification	
Body	SS316 / A479	BRASS / B16
Spring	SS302	
Gasket	Silver-plated SS316 / A240	Aluminum / B209
Filter Elements	SS316 Sintered	

Technical Data

Maximum Operating Pressure :
3000 PSI (207 bar) @ 70 °F (21 °C)

Operating Temperature Range:
From -20 °F to 900 °F (-28 °C to 482 °C) with SS316 body
and up to 300 °F (148 °C) with Brass body

Effective Filtration Area:

Series	Effective Filtration Area
F11	0.55 sq. in. (0.00035 sq. meter)
F12	1.30 sq. in. (0.00083 sq. meter)
F13, F14	2.0 sq. in. (0.00128 sq. meter)

Filter elements

Elements remove 95% of particles larger than the nominal pore size.

Nominal pore Size μm	Pore Size Range μm
0.5	0.5 to 2
2	1 to 4
7	5 to 10
15	11 to 25
60	50 to 75
90	75 to 100

Operation and Filter Replacement

The filter element, which is made of sintered stainless steel, is porous and has lots of tiny holes. Particles bigger than the pores are not allowed to pass through, hence clean system media. After a certain period, the holes may be blocked by particles and pressure drop will increase. This depends upon the total flow through the elements and cleanliness of upstream flow. The element needs to be replaced for clean system media with minimal pressure drop.

Flow Data at 70 °F (20 °C)

Nominal Element Pore Size μm	Inlet Pressure, psig (bar)			Pressure Drop, psig (bar)		
	5 (0.34)	10 (0.68)	15 (1.0)	10 (0.68)	50 (3.4)	100 (6.8)
	Air Flow, std in ³ /min (std L/min)			Water Flow, std in ³ /min (std L/min)		
0.5	67.13 (1.1)	103.76 (1.7)	207.49 (3.4)	1.83 (0.03)	9.15 (0.15)	27.46 (0.45)
2	341.75 (5.6)	671.30 (11)	1037.46 (17)	18.30 (0.30)	55.53 (0.91)	91.54 (1.5)
7	854.38 (14)	1525.68 (25)	2074.92 (34)	22.58 (0.37)	67.13 (1.1)	109.85 (1.8)
15	1342.59 (22)	2196.97 (36)	2563.13 (42)	27.46 (0.45)	79.34 (1.3)	128.16 (2.1)
60	2929.30 (48)	3783.67 (62)	4149.84 (68)	34.18 (0.56)	109.85 (1.8)	158.67 (2.6)
90	3112.38 (51)	3783.67 (62)	4454.97 (73)	45.77 (0.75)	109.85 (1.8)	134.26 (2.2)



HY-LOK CORPORATION

© 1998, 1999, 2000, 2002, 2003, 2004 HY-LOK CORPORATION All rights reserved

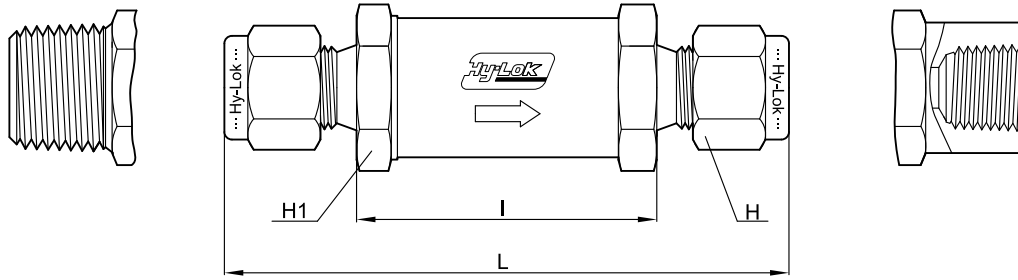

Table of Dimensions

Basic Part No.		Orifice in. (mm)	End Connection		Dimensions, in.(mm)				
Series	Part No.		Inlet	Outlet	L	I	H	H ₁	
FI 1	H - 2T -	0.094 (2.4)	1/8 Hy-Lok	1/8 Hy-Lok	2.35 (59.7)	1.15 (29.2)	7/16 (11.1)	9/16 (14.3)	
	M - 2N -		1/8 Male NPT	1/8 Male NPT	1.91 (48.6)		-		
	F - 2N -		1/8 Female NPT	1/8 Female NPT	2.16 (54.9)		-		
	H - 3M -		3mm Hy-Lok	3mm Hy-Lok	2.38 (60.5)		0.47 (12.0)		
FI 2	H - 4T -	0.187 (4.8)	1/4 Hy-Lok	1/4 Hy-Lok	2.96 (75.2)	1.56 (39.7)	9/16 (14.3)	3/4 (19.0)	
	M - 4N -		1/4 Male NPT	1/4 Male NPT	2.69 (68.3)		-		
	F - 4N -		1/4 Female NPT	1/4 Female NPT	2.87 (72.9)		-		
	H - 6M -		6mm Hy-Lok	6mm Hy-Lok	2.96 (75.2)		0.55 (14.0)		
FI 3	H - 8M -	0.281 (7.1)	8mm Hy-Lok	8mm Hy-Lok	3.02 (76.64)	1.70 (43.2)	0.63 (16.0)	1 (25.4)	
	H - 6T -		3/8 Hy-Lok	3/8 Hy-Lok	3.22 (81.8)		11/16 (17.4)		
	M - 6N -		3/8 Male NPT	3/8 Male NPT	2.82 (71.6)		-		
	F - 6N -		3/8 Female NPT	3/8 Female NPT	3.04 (77.2)		-		
FI 4	H - 10M -	0.409 (10.4)	10mm Hy-Lok	10mm Hy-Lok	3.34 (84.74)	1.80 (45.7)	0.75 (19)	1 (25.4)	
	H - 12M -		12mm Hy-Lok	12mm Hy-Lok	3.53 (89.57)		8.66 (22)		
	H - 8T -		1/2 Hy-Lok	1/2 Hy-Lok	3.42 (86.9)		1.70 (43.2)		7/8 (22.2)
	F - 8N -		1/2 NPT	1/2 NPT	3.26 (82.9)		1.76 (44.7)		-
FI 4	H - 10M -	0.409 (10.4)	10mm Hy-Lok	10mm Hy-Lok	3.24 (82.2)	1.70 (43.2)	0.75 (19.0)	1 (25.4)	
	H - 16M -		16mm Hy-Lok	16mm Hy-Lok	3.60 (91.5)		1.76 (47.7)		0.98 (25)

Dimensions shown with Hy-Lok nuts in finger-tight position, where applicable.

Ordering Information

FI

Series Designator

- FI 1 : Orifice 0.094 (2.4)
- FI 2 : Orifice 0.187 (4.8)
- FI 3 : Orifice 0.281 (7.1)
- FI 4 : Orifice 0.409 (10.4)

F

End Connection Designator

- H : Hy-Lok Tube Fitting
- M : Male Pipe Thread
- F : Female Pipe Thread

4N

Size Designator

15

Fiter Element Designator

- 05 : 0.5 Micron
- 2 : 2 Micron
- 7 : 7 Micron
- 15 : 15 Micron
- 60 : 60 Micron
- 90 : 90 Micron

S316

Body Material Designator

- S316 : 316 Stainless Steel
- BRAS : brass

■ **NPT (ISO / BSP)**

Thread (in)	1/8	1 / 4	3/8	1 1/2	3 / 4
Designation	2N(R)	4N(R)	6N(R)	8N(R)	12N

■ **Tube O.D. Designation**

Inch	Tube O.D.	1 / 8	1/4	3/8	1/2
	Designation	2	4	6	8
Tube	Tube O.D.	3mm	6mm	10mm	12mm
	Designation	3M	6M	10M	12M

SAFETY in VALVE SELECTION

Proper installation, materials compatibility, operation and maintenance of these valves are the responsibility of the user. The total system design must be taken into consideration to ensure optimal performance and safety.