



DV Series

Diaphragm Valves



Design and Engineering

- 316L Stainless Steel (Single & Double Melt)
- Low and High Pressure Model
- ZCR, Tube Butt Weld, and Hy-Lok Tube End Connections
- Manual Handle or Pneumatic Actuator
- 100% Helium Leak Tested

Applications

- Ultrahigh Purity Process
- Semiconductor
- Biotech
- Pharmaceutical

Diaphragm Valves

Features

Body

- 316L Stainless Steel (Single & Double Melt)
- Minimum dead space
- Maximum flow capacity
- Electro polishing processing

Diaphragm

- Elgiloy® material
- Excellent corrosion resistance
- Electro polishing processing
- Long cycle life

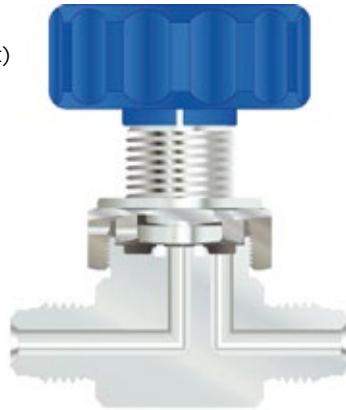

Seat

- Excellent chemical resistance
- Low coefficient for thermal expansion
- Minimum particle of contamination
- Long cycle life

Manual Handle and Pneumatic Actuators

Manual Handle

- 1/4" Aluminum type handle rotates 90°
- Otherwise 3/4" Aluminum type and all different size of ABS (100) type handle rotate 180°
- Low pressure model are applicable blue color handle
- High pressure model are applicable white color handle
- Visually OPEN and CLOSE positions confirm by handle window
- This handle are available on low and high pressure model



Round Handle



Directional Handle



Locking Handle

Pneumatic Actuator

- Low pressure model
- Max. working pressure: 250 psig (17.2 barg)
- Flow coefficient: 0.27
- Actuation pressure: 60~120 psig (4.2~8.2 barg)



- High pressure model!
- Max. working pressure: 3,000 psig (207 barg)
- Flow coefficient: 0.1
- Actuation pressure: 70~120 psig (4.9~8.2 barg)



Materials of Construction

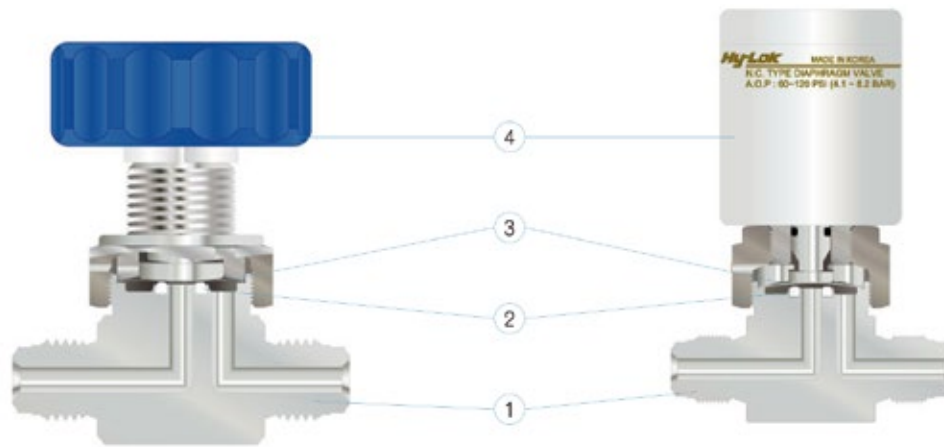

No.	Parts	Material / ASTM Specification	
		DV Series	
		Manual	Pneumatic
1*	Body	A182 Type F316L (Single & Double Melt) / A479 Type 316L (Single & Double Melt)	
2*	Seat	PCTFE (D1430)	
3*	Diaphragm	Elgiloy® (F1058, AMS5876)	
4	Actuation	ABS (100)/Aluminum	Aluminum

* marked are wetted parts.

ABS (100) Handle are manual actuation and Low pressure only.

Specification

Model	Size	Pressure Rating psig (bar)	Temp. Rating C (F)	Flow Coefficient Cv	Orifice (mm)
Low Pressure	1/4"	250 (17.2 barg)	-23 ~ 65 (-10 ~ 150)	0.27	4.1
	3/8"			0.7	7,0
	1/2"				
	3/4"				
High Pressure	1/4"	3000 (203 barg)		0.1	2.5

Diaphragm Valves

Dimensions

All dimensions are in millimeters and for reference only. In case of the end connection for Hy-Lok tube fitting, dimensions shown with Hy-Lok nuts in finger-tight position, where applicable.

Low Pressure Models

Manual Round Handle

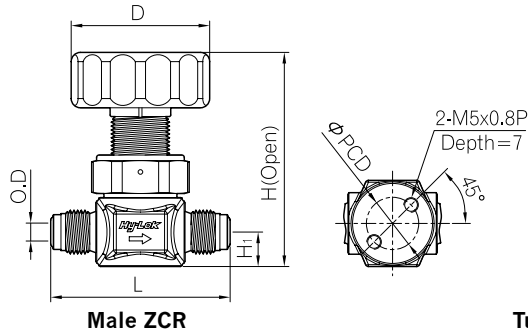

Upper (Handle Operating)

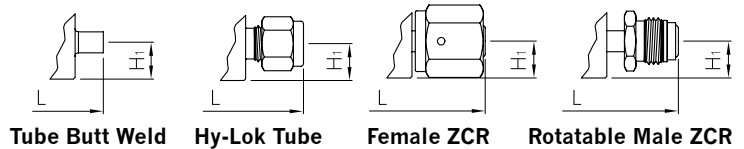
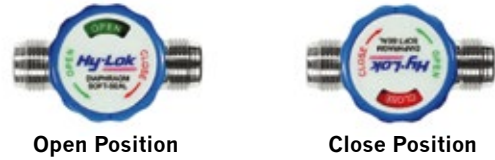

End Connection	Ordering No.	O.D.	L	H ₁	H	D	PCD
Male ZCR Fitting	DVVM- 4-AH	1/4"	58.4	11.2	70.6	40.0	17.0
	DVVM- 8-AH	1/2"	76.0	16.0	78.2		28.0
	DVVM-12-AH	3/4"	88.0	22.0	91.7		
Rotatable Male ZCR Fitting	DVRM- 4-AH	1/4"	70.6	11.2	70.6	40.0	17.0
	DVRM- 8-AH	1/2"	83.0	16.0	78.2		28.0
	DVRM-12-AH	3/4"	106.0	22.0	91.7		
Female ZCR Fitting	DVVF- 4-AH	1/4"	70.6	11.2	70.6	40.0	17.0
	DVVF- 8-AH	1/2"	83.0	16.0	78.2		28.0
	DVVF-12-AH	3/4"	106.0	22.0	91.7		
Hy-Lok Tube Fitting	DVH- 4-AH	1/4"	64.4	11.2	70.6	40.0	17.0
	DVH- 8-AH	1/2"	81.8	16.0	78.2		28.0
	DVH-12-AH	3/4"	80.8	22.0	91.7		
Tube Butt Weld	DVBW- 4-AH	1/4"	44.2	11.2	70.6	40.0	17.0
	DVBW- 8-AH	1/2"	68.0	16.0	78.2		28.0
	DVBW-12-AH	3/4"	73.6	22.0	91.7		

Handle color for Low pressure model is Blue. All dimensions are in millimeters and for reference only.

Manual Directional Handle

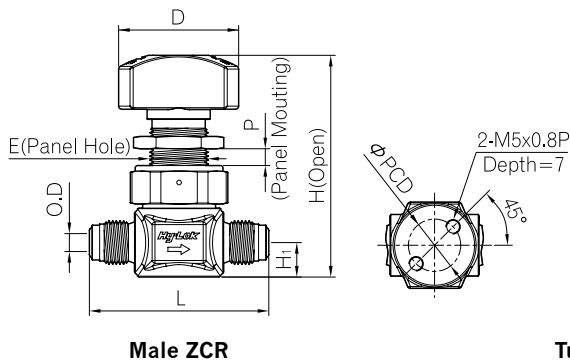

Upper (Handle Operating)

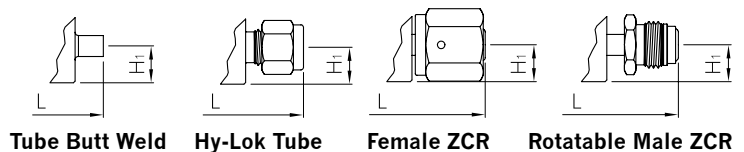
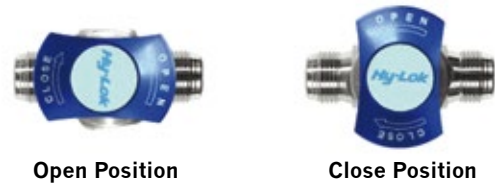

End Connection	Ordering No.	O.D.	L	H ₁	H	D	E	P	PCD
Male ZCR Fitting	DVVM-4-DR	1/4"	58.4	11.2	73.0	39.0	20.0	6.0	17.0
Rotatable Male ZCR Fitting	DVRM-4-DR		70.6						
Female ZCR Fitting	DVVF-4-DR		70.6						
Hy-Lok Tube Fitting	DVH-4-DR		64.4						
Tube Butt Weld	DVBW-4-DR		44.2						

Handle color for Low pressure model is Blue. All dimensions are in millimeters and for reference only.

Low Pressure Models

Manual Round Handle

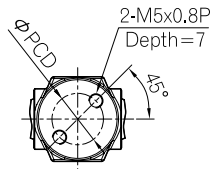
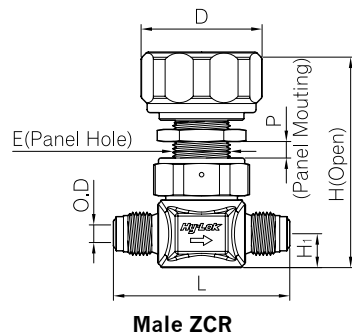

Upper (Handle Operating)



Open Position

Close Position

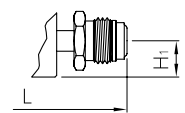
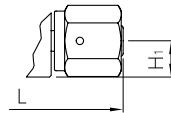
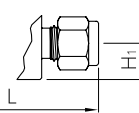
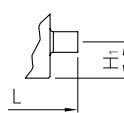

Tube Butt Weld

Hy-Lok Tube

Female ZCR

Rotatable Male ZCR

End Connection	Ordering No.	O.D.	L	H ₁	H	D	E	P	PCD
Male ZCR Fitting	DVVM- 4	1/4"	58.4	11.2	72.1	40.0	20.0	6.0	17.0
	DVVM- 8	1/2"	76.0	16.0	80.2		23.1	7.0	28.0
	DVVM-12	3/4"	88.0	22.0	93.1				
Rotatable Male ZCR Fitting	DVRM- 4	1/4"	70.6	11.2	72.1	40.0	20.0	6.0	17.0
	DVRM- 8	1/2"	83.0	16.0	80.2		23.1	7.0	28.0
	DVRM-12	3/4"	106.0	22.0	93.1				
Female ZCR Fitting	DVVF- 4	1/4"	70.6	11.2	72.1	40.0	20.0	6.0	17.0
	DVVF- 8	1/2"	83.0	16.0	80.2		23.1	7.0	28.0
	DVVF-12	3/4"	106.0	22.0	93.1				
Hy-Lok Tube Fitting	DVH- 4	1/4"	64.4	11.2	72.1	40.0	20.0	6.0	17.0
	DVH- 8	1/2"	81.8	16.0	80.2		23.1	7.0	28.0
	DVH-12	3/4"	80.8	22.0	93.1				
Tube Butt Weld	DVBW- 4	1/4"	44.2	11.2	72.1	40.0	20.0	6.0	17.0
	DVBW- 8	1/2"	68.0	16.0	80.2		23.1	7.0	28.0
	DVBW-12	3/4"	73.6	22.0	93.1				

Handle color for Low pressure model is Blue. All dimensions are in millimeters and for reference only.

Manual Locking Type Handle

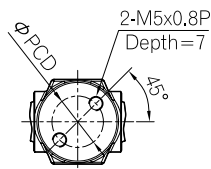
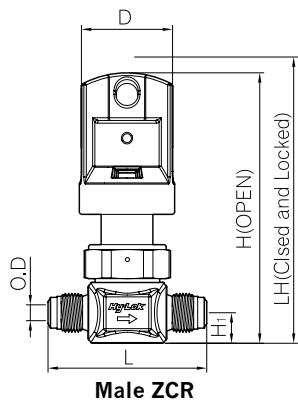

Upper (Handle Operating)



Open Position

Close Position

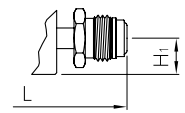
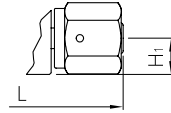
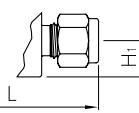
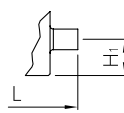

Tube Butt Weld

Hy-Lok Tube

Female ZCR

Rotatable Male ZCR

End Connection	Ordering No.	O.D.	L	H ₁	H	D	PCD
Male ZCR Fitting	DVVM-4-LK	1/4"	58.4	11.2	73.0	39.0	17.0
Rotatable Male ZCR Fitting	DVRM-4-LK		70.6				
Female ZCR Fitting	DVVF-4-LK		70.6				
Hy-Lok Tube Fitting	DVH-4-LK		64.4				
Tube Butt Weid	DVBW-4-LK		44.2				

Handle color for Low pressure model is Blue. All dimensions are in millimeters and for reference only.

Diaphragm Valves

High Pressure Models

Manual Round Handle

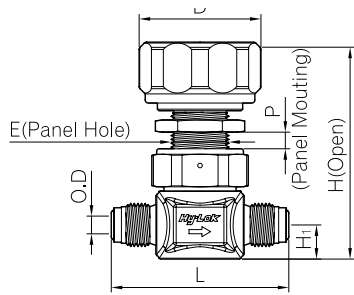

Male ZCR

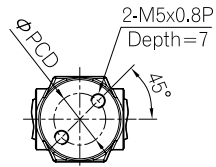

Upper (Handle Operating)



Open Position



Close Position

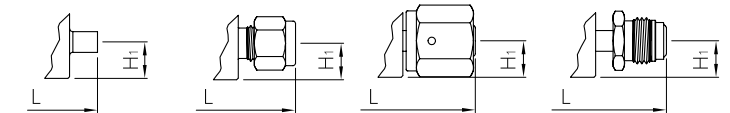

Tube Butt Weld Hy-Lok Tube Female ZCR Rotatable Male ZCR

End Connection	Ordering No.	O.D.	L	H ₁	H	D	E	P	PCD
Male ZCR Fitting	DVHPVM-4	1/4"	58.4	11.2	72.1	40.0	20.0	6.0	17.0
Rotatable Male ZCR Fitting	DVHPRM-4		70.6						
Female ZCR Fitting	DVHPVF-4		70.6						
Hy-Lok Tube Fitting	DVHPH-4		64.4						
Tube Butt Weid	DVHPBW-4		44.2						

Handle cap color for high pressure model is Gold.

Manual Directional Handle

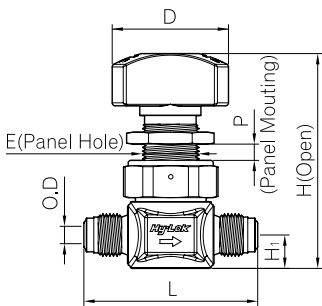

Male ZCR

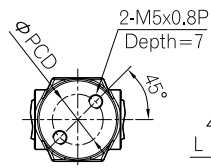

Upper (Handle Operating)



Open Position



Close Position

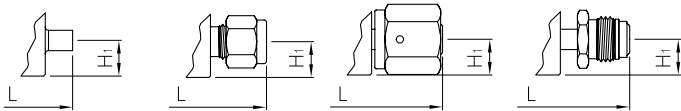

Tube Butt Weld Hy-Lok Tube Female ZCR Rotatable Male ZCR

End Connection	Ordering No.	O.D.	L	H ₁	H	D	E	P	PCD
Male ZCR Fitting	DVHPVM-4-DR	1/4"	58.4	11.2	73.0	39.0	20.0	6.0	17.0
Rotatable Male ZCR Fitting	DVHPRM-4-DR		70.6						
Female ZCR Fitting	DVHPVF-4-DR		70.6						
Hy-Lok Tube Fitting	DVHPH-4-DR		64.4						
Tube Butt Weid	DVHPBW-4-DR		44.2						

Handle cap color for high pressure model is Gold.

Manual Locking Type Handle

Upper (Handle Operating)

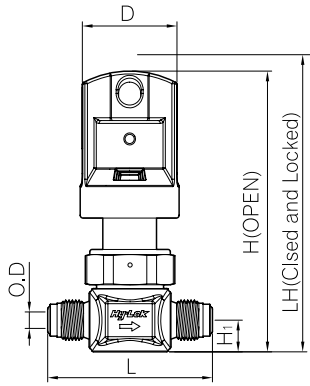

Male ZCR

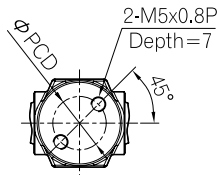

Open Position



Close Position

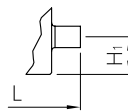

Tube Butt Weld

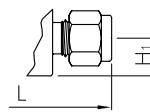

Hy-Lok Tube

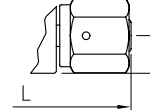

Female ZCR

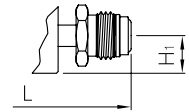

Rotatable Male ZCR

End Connection	Ordering No.	O.D.	L	H _i	H	D	E	PCD
Male ZCR Fitting	DVHPVM-4-LK	1/4"	58.4	11.2	99.5	39.0	20.0	17.0
Rotatable Male ZCR Fitting	DVHPRM-4-LK		70.6					
Female ZCR Fitting	DVHPVF-4-LK		70.6					
Hy-Lok Tube Fitting	DVHPH-4-LK		64.4					
Tube Butt Weid	DVHPBW-4-LK		44.2					

Handle cap color for high pressure model is Gold.

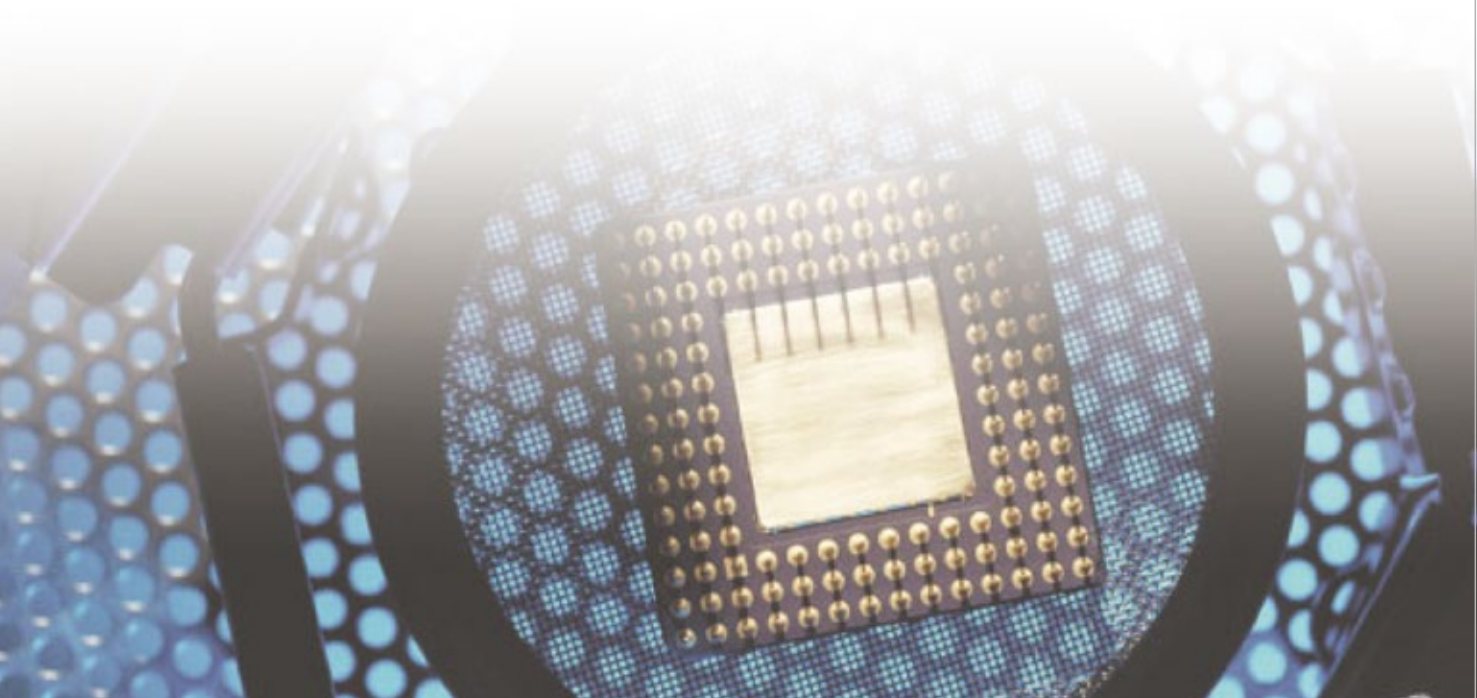

Diaphragm Valves

Dimensions

All dimensions are in millimeters and for reference only. In case of the end connection for Hy-Lok tube fitting, dimensions shown with Hy-Lok nuts in finger-tight position, where applicable.

Low Pressure Models Pneumatic Actuator

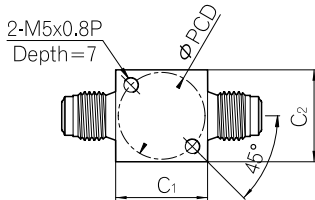
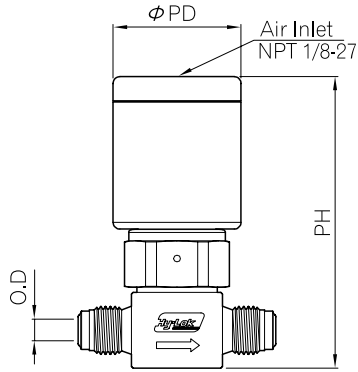

Ordering No.	O.D.	Description	PH	PD
DVVM- 4-PC	1/4"	Normally Close	86	38
DVVM- 8-PC	1/2"		94	45
DVVM-12-PC	3/4"		104	
DVVM- 4-PO	1/4"	Normally Open	86	38
DVVM- 8-PO	1/2"		94	45
DVVM-12-PO	3/4"		104	

For end connection types and dimensions are same as manual Handle.

High Pressure Models Pneumatic Actuator

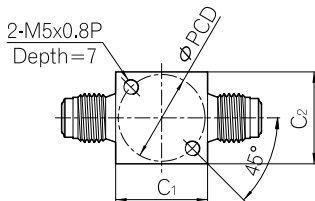
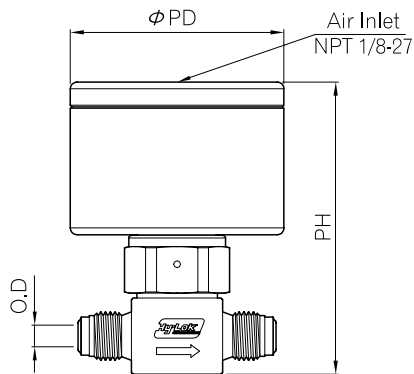

Ordering No.	O.D.	Description	PH	PD
DVHPVM-4-PC	1/4"	Normally Close	98.8	63
DVHPVM-8-PC	1/4"	Normally Open	98.8	63

For end connection types and dimensions are same as manual Handle.

Multiport Diaphragm Valves

To customize this model to meet your system requirements, select designators for:

- multiport flow path
- end connector for each port
- internal surface grade
- manual handle or pneumatic actuator

Multiport Flow Path

Ports No.	Designator	Schematic	Flow Path	
			Close	Open
4	L			
	N			
3	C			
	E			
	R			
	T			
	Y			
	J			
2	Q			
	U			

- The flow path is shown as viewed from the top of the valve body.
- The „a“ next to the port number indicate that a port is above the valve seat.
- The „b“ next to the port number indicate that a port is below the valve seat.



Dimension

All dimensions are in millimeters and for reference only. In case of the end connection for Hy-Lok tube fitting, dimensions shown with Hy-Lok nuts in finger-tight position, where applicable.

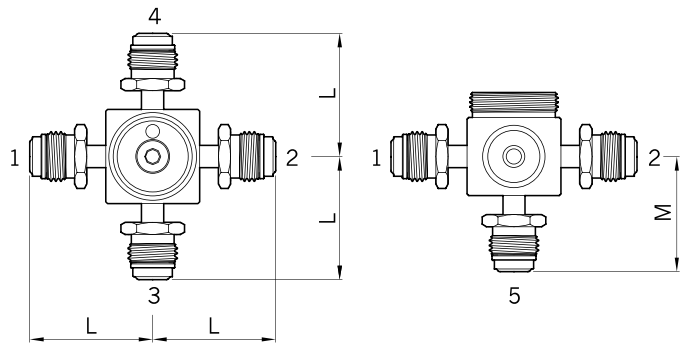

End Connection	O.D.	L	M
Tube Butt Weld (Tube wall, 0.035 in.)		22.1	19.3
Female ZCR Fitting	1/4"	35.3	41.4
Rotatable Male ZCR Fitting		35.3	41.4

The end connection designators are reference on page 8. The dimension of four bottom mounting holes are same as standard 2 port valve body on page 4. The flow path designator „Q“ is no mounting holes.

Example Ordering Information

Ordering No.	DVLMFMF-4-H	DVHPCFWF-4-H	DVJWW-4-PC-H
Material	I 316L Stainless Steel (Single & Double Melt)		
Model Series	Low Pressure, 1/4"	High Pressure, 1/4"	Low Pressure, 1/4"
Flow Path	4 ports, L	3 ports, C	2 ports, J
Port No. 1 End Connection	Rotatable Male ZCR Fitting	Female ZCR Fitting	Tube Butt Weld
Port No. 2 End Connection	Female ZCR Fitting	Tube Butt Weld	-
Port No. 3 End Connection	Rotatable Male ZCR Fitting	Female ZCR Fitting	-
Port No. 4 End Connection	Female ZCR Fitting	-	Tube Butt Weld
Actuation Method	Manual Handle, Color Blue	Manual Handle, Color White	Normally Close

Handle cap color for low pressure model is Blue.

Diaphragm Valves

Manifolds Diaphragm Valves

To customize this model to meet your system requirements, select designators for:

- manifold flow path end connector for each port
- internal surface grade manual handle or pneumatic actuator

Multiport Flow Path

Manifold	Designator	Schematic	Flow Path
2 Valve & 3 Port Mono Block	M1		
	M2		
2 Valve & 3 Port Double Pattern	M3		



Dimension

All dimensions are in inches (millimeters) and for reference only. In case of the end connection for Hy-Lok tube fitting, dimensions shown with Hy-Lok nuts in finger-tight position, where applicable.

2 Valve & 3 Port Monoblock

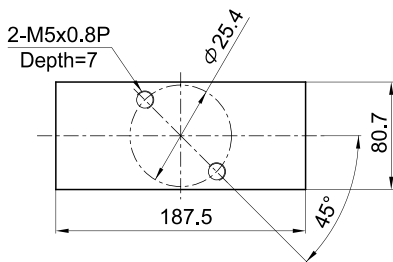
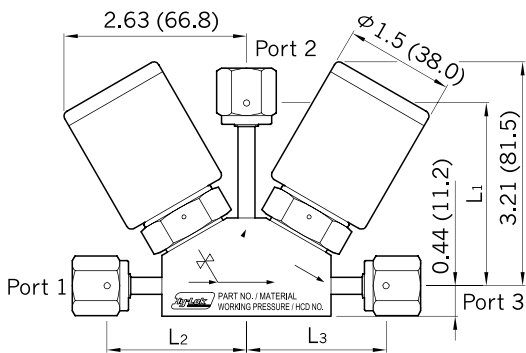

2 Valve & 3 Port Double Pattern

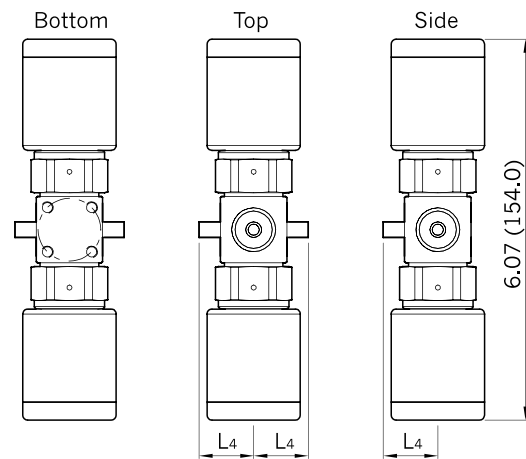

End Connection	O.D.	2 Valve & 3 Port Mono Block			2 Valve & 3 Port Double Pattern
		L1	L2	L3	L4
Tube Butt Weld (Tube wall, 0.035 in.)		46.0	70.9	46.0	22.1
Female ZCR Fitting	1/4"	51.6	67.6	51.6	35.3
Rotatable Male ZCR Fitting		60.7	85.1	60.7	35.3

The end connection designators are reference on next page.

Example Ordering Information

Ordering No.	DVM1FMF-4-PCO-H	DVHPM2WWW-4-H	DVM3MFF-4-H
Material	316L VIM / VAR Stainless Steel		
Model Series	Low Pressure, 1/4"	High Pressure, 1/4"	Low Pressure, 1/4"
Flow Path	2 Valve & 3 port Monoblock, M1	2 Valve & 3 port Monoblock, M2	2 Valve & 3 port Double Pattern, M3
Port No. 1 End Connection	Female ZCR Fitting	Tube Butt Weld	Rotatable Male ZCR Fitting
Port No. 2 End Connection	Rotatable Male ZCR Fitting	Tube Butt Weld	Female ZCR Fitting
Port No. 3 End Connection	Female ZCR Fitting	Tube Butt Weld	Female ZCR Fitting
Valve 1 Actuation Method	Normally Close	Manual Handle, Color White	Manual Handle, Color Blue
Valve 2 Actuation Method	Normally Open	Manual Handle, Color White	Manual Handle, Color Blue

Maintenance Kits

To disassemble or assemble the maintenance kits, refer to the Hy-Lok Corporation document no. H-DV100-IM.

Diaphragm Kits



- Two diaphragms are maintenance kits.
- Ordering number is DVDM-4-KITS (1/4" size)
DVDM-8-KITS (1/2" and 3/4" size)
DVHPDM-4-KITS (1/4" High Pressure)

Pneumatic Actuator Kits

Ordering number is the following.

Model	Ordering No.	O.D Size	Description I
Low Pressure	DV-4-PO	1/4"	Normally Open
	DV-4-PC		Normally Close
	DV-8-PO	1/2", 3/4"	Normally Open
	DV-8-PC		Normally Close
High Pressure	DVH-4-PO	1/4"	Normally Open
	DVH-4-PC		Normally Close

⚠ Do not interchange high pressure actuator and low pressure actuator.

Ordering Information

DV

Valve Series Designator

- DV - Forged Diaphragm Valve
- DV2 - Square Diaphragm Valve

HP

Model

- Nil - Low Pressure
- HP - High Pressure

M1

Flow Path

- Nil - Standard (page 3-8)
- Multiport & Manifold flow path Designators are reference on page 9,10

VFF

End Connection

End Connection	Standard	Multiport & Manifold
Male ZCR Fitting	VM	-
Tube Butt Weld	BW	W
Female ZCR Fitting	VF	F
Hy-Lok Tube Fitting	H	-
Rotatable Male ZCR	RM	M

4

Size

- 4 - 1/4"
- 6 - 3/8"
- 8 - 1/2"
- 12 - 3/4"

PCO

Actuation

- Nil - Standard Round Handle
- PO - Pneumatic Actuator (Normally Open)
- PC - Pneumatic Actuator (Normally Close)
- PCO - Valve 1: Normally Close, Valve 2: Normally Open
- POC - Valve 1: Normally Open, Valve 2: Normally Close
- DR - Directional Handle
- LK - Loking Handle
- AH - ABS(100) Handle

H

Surface Grade

- Nil - B.A (Bright Analing)
- H - EP (Electro Polishing)

VV6L

Body Material Designator

- SM6L : Single Melting 316L
- VV6L : Double Melting 316L

