



www.hy-lok.com

Catalog No. H-CNG100
April 2014



CNG Products

Receptacles, Ball & Check Valves
Filters, Tube Fittings



- ECE R110 & AGA / CGA NGV Compliant for NGV application.
- 100% factory tested



HY-LOK CORPORATION

© 2007, 2014 HY-LOK CORPORATION All rights reserved

Introduction

Hy-Lok's receptacle is designed for permanent mounting to a compressed natural gas vehicle (NGV). QC1 Series receptacle utilizes the AGA / CGA NGV 1 profile allowing complete interchangeability to any nozzle conforming to the AGA / CGA NGV 1 standard. Tested and certified for this application per AGA / CGA NGV 1 & ECE R110 QC2 Series receptacle is designed specifically for bus and trucks refuelling, receptacle is designed to provide superior flow characteristics.

Features

- Receptacle contains a highly reliable non-contact check valve that opens only when differential pressure is present during fueling.
- Internal check valve provides unidirectional flow.
- Construction material - available in stainless steel or brass.
- Self-Centering Poppet.
- Standard protective dust caps are supplied with all receptacles.
- Optionally with particle filter available (50 Micron).

Technical Data

- Maximum Operating Pressure : 3600 psig (250 bar) @ 100 °F (38 °C)
- Operating Temperature Range : From -40 °F to 250 °F (-40 °C to 121 °C)

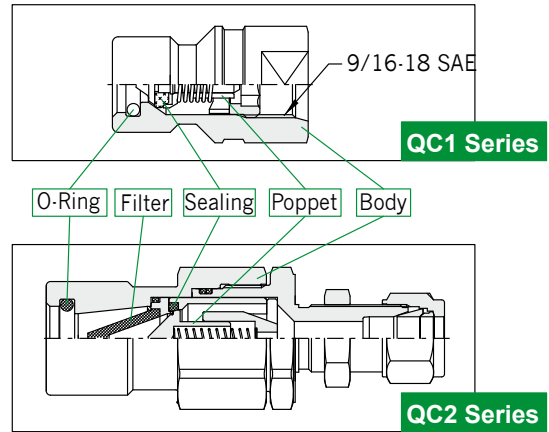

Material of Construction

Description	Material / ASTM Specification	
Body	SS316 / A479	BRASS / B16
Poppet	SS316 / A479	
Sealing	NBR	
O-Ring	NBR	

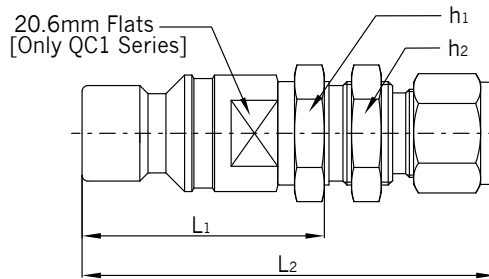

Table of Dimensions

Basic Part No.	End Connection	Width across flat				Dimensions in. (mm)	
		h1		h2		L1	L
		in.	mm	in.	mm		
QC1CB - 4	1/4 Hy-Lok	11/16	17.4	5/8	15.8	1.91" (48.5)	3.23" (82.0)
QC1CB - 6	3/8 Hy-Lok	3/4	19.1	3/4	19.1	1.96" (49.8)	3.41" (86.6)
QC1CB - 8	1/2 Hy-Lok	1	25.4	1	25.4	2.05" (52.0)	3.48" (88.4)
QC1CB - 6M	6M Hy-Lok	-	18.0	5/8	15.8	1.91" (48.5)	3.23" (82.1)
QC1CB - 10M	10M Hy-Lok	-	22.0	-	22.0	1.96" (49.8)	3.41" (86.8)
QC1CB - 12M	12M Hy-Lok	-	24.0	15/16	23.8	2.05" (52.0)	3.49" (88.6)
QC2CB - 12M	12M Hy-Lok	-	36.0	15/16	23.8	2.74" (69.5)	4.39" (111.4)
QC2CB - 16M	16M Hy-Lok	-	36.0	-	27.0	2.74" (69.5)	4.41" (112.1)

* Dimensions shown with Hy-Lok nuts in finger-tight position, where applicable.

Ordering Information

QC1

Series Designator

- QC1: NGV 1 Receptable
- QC2: For Buses and Trucks

CB

End Connection Designator

- CB: Hy-Lok Tube Fitting
- CBZ: O-Ring Face Seal

4

Size Designator

Tube O.D. Designation

Tube O.D.	1/4"	3/8"	1/2"	6mm	10mm	12mm	16mm
Designation	4	6	8	6M	10M	12M	16M

S316

Body Material Designator

- S316: 316 Stainless Steel
- BRAS: Brass

Introduction

Hy-Lok's CNG Series Manual Ball Valves are designed to live loaded type for long cycle life and high pressure.

The valves provide quick 1/4 turn on-off control of flow the vehicle tank to the engine.

Tested and certified for this application per AGA / CGA NGV 3.1. & ECE R110

Features

- Disc spring loaded seat
- Low operating pressure
- Handle indicates direction of flow
- Panel mounting
- 1/4 turn on-off control
- 316 Stainless Steel construction
- Bi-directional flow
- 100% factory tested

Technical Data

- Maximum Operating Pressure : 6000 psig(414 bar) @ 100 °F (38 °C)
- Operating Temperature Range : From -40 °F to 250 °F (-40 °C to 121 °C)
- Cv Ratings : 1.04 to 5.39

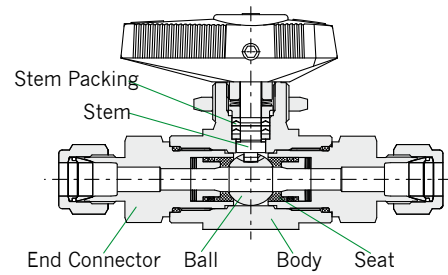

Material of Construction

Description	Material / ASTM Specification
Body	SS316 / A182 or A479
End Connection	SS316 / A479
Ball	SS316 / A479
Stem	SS316 / A479
Stem Packing	PCTFE
Seats	PEEK
Seals	Viton

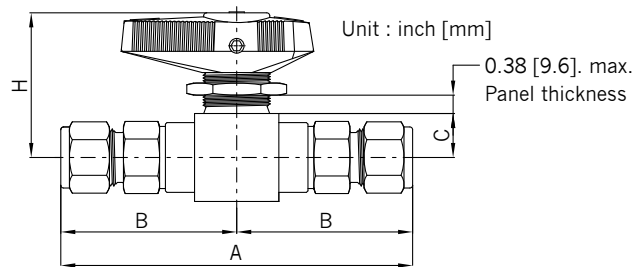

Table of Dimensions

Basic Part Number	Orifice in. (mm)	Cv	End Connections		Dimensions, in. (mm)				
			Inlet	Outlet	A	B	C	H	
CNG1B	H - 4T	0.188 (4.8)	1.04	1/4" Hy-Lok	1/4" Hy-Lok	4.14 (105.2)	2.07 (52.6)	0.57 (14.5)	0.71 (18.0)
	H - 6T	0.244 (6.2)	2.30	3/8" Hy-Lok	3/8" Hy-Lok	4.39 (111.2)	2.19(55.6)		
	H - 8T			1/2" Hy-Lok	1/2" Hy-Lok	4.60 (116.8)	2.30 (58.4)		
CNG2B	H - 8T	0.362 (9.2)	5.39	1/2" Hy-Lok	1/2" Hy-Lok	4.68 (118.8)	2.34 (59.4)	0.71 (18.0)	2.50 (63.5)
	H -12T			3/4" Hy-Lok	3/4" Hy-Lok				
CNG1B	H - 6M	0.188 (4.8)	1.04	6mm Hy-Lok	6mm Hy-Lok	4.14 (105.2)	2.07 (52.6)	0.57 (14.5)	1.89 (48.4)
	H -10M	0.244 (6.2)	2.30	10mm Hy-Lok	10mm Hy-Lok	4.40 (111.8)	2.20 (55.9)		
	H -12M			12mm Hy-Lok	12mm Hy-Lok	4.60 (116.8)	2.30 (58.4)		
CNG2B	H -12M	0.3.62 (9.2)	5.39	12mm Hy-Lok	12mm Hy-Lok	4.68 (118.8)	2.34 (59.4)	0.71 (18.0)	2.50 (63.5)
	H -16M			16mm Hy-Lok	16mm Hy-Lok				

* Dimensions shown with Hy-Lok nuts in finger-tight position, where applicable.

Ordering Information

CNG1B

Series Designator

- CNG1B : Orifice 6.2mm
- CNG2B : Orifice 9.2mm

H

End Connection Designator

- H: Hy-Lok Tube Fitting
- F: Female Thread

4T

Size Designator

NPT (ISP/BSP)

Pipe Size	1/8"	3/4"
Designation	2N (R)	2N (R)

Tube O.D. Designation

Tube O.D.	1/4"	3/8"	1/2"	6mm	8mm	10mm	12mm
Designation	4T	6T	8T	6M	8M	10M	12M

S316

Body Material Designator

- S316: 316 Stainless Steel

Introduction

Hy-Lok's 700H Series Check Valves are designed for flow control CNG. Tested and certified for this application per AGA/CGA NGV 3.1. & ECE R110

Features

- Inline check valve.
- Back stopped pppet.
- NBR seat design.
- Cracking pressure inclue : 1/3, 1, 5, 10, 25psig.
- Indicator Ring for easy identify the cracking pressure.
- 100% factory tested.

Technical Data

- Maximum Operating Pressure : 6000 psig (414 bar) @ 100°F (38°C)
- Operating Temperature Range : From -40°F to 250°F (-40°C to 121°C)
- Flow Coefficient (Cv): 0.67 to 4.7

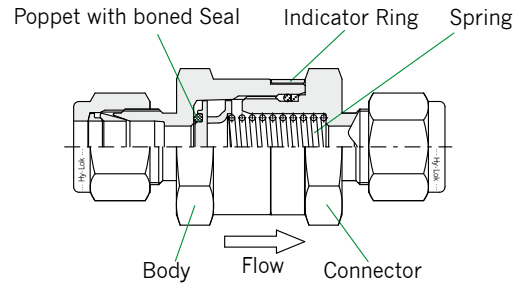

Material of Construction

Description	Material / ASTM Specification
Body	SS316 / A479
Connector	SS316 / A479
Sealing	NBR
Spring	SS302
Indicator Ring	Stainless Steel

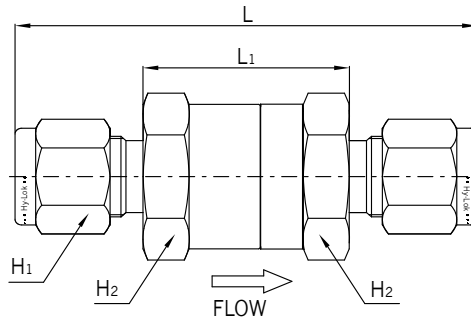

Table of Dimensions

Basic Part No.	End Connection	Hexagon, in. (mm)				Dimensions, in. (mm)	
		h1		h2		L1	L
		in.	mm	in.	mm		
CVH1 · H4T	1/4 Hy-Lok	9/16	14.20	11/16	17.46	1.04" (26.4)	2.43" (61.7)
CVH1 · ZC04	1/4" O-Ring Face Seal	-	-	-	-	-	1.98" (50.3)
CVH2 · H8T	1/2" Hy-Lok	3/4	22.22	1	25.40	1.23" (31.2)	2.96" (75.2)
CVH2 · H8M	1/2" Hy-Lok	3/4	16.00				2.70" (68.6)
CVH2 · H10M	10mm Hy-Lok	-	19.00				2.80" (71.1)
CVH2 · H12M	12mm Hy-Lok	-	22.00				2.96" (75.2)
CVH2 · H16M	16mm Hy-Lok	-	25.00			1.42" (36.0)	3.15" (80.0)
CVH2 · ZC08	1/2" O-Ring Face Seal	-	-			1.23" (31.2)	2.35" (59.7)
CVH3 · H12T	3/4" Hy-Lok	1 1/8"	28.58			1 5/8"	41.28
CVH3 · ZC012	3/4" O-Ring Face Seal	-	-	1.78" (45.2)	2.90" (73.7)		

* Dimensions shown with Hy-Lok nuts in finger-tight position, where applicable.

Ordering Information

CVH1

Series Designator

- CVH1 : Orifice 4.8mm
- CVH2 : Orifice 7.8mm
- CVH3 : Orifice 15.2mm

H

End Connection Designator

- H : Hy-Lok Tube Fitting
- F : Female Thread
- M : Male Thread
- V : Metal Gasket Face Seal
- ZCO : O-Ring Face Seal

4T

Size Designator

1/3

End Connection Designator

- 1/3 : 1/3 psig
- 1 : 1 psig
- 5 : 5 psig
- 10 : 10 psig
- 25 : 25 psig

S316

Body Material Designator

- S316: 316 Stainless Steel

■ NPT (ISP/BSP)

Pipe Size	1/8"	3/4"
Designation	2N(R)	2N(R)

■ Tube O.D. Designation¹

Tube O.D.	1/4"	3/8"	1/2"	3/4"	8mm	10mm	12mm	16mm
Designation	4T	6T	8T	12T	8M	10M	12M	16M

Filter

Introduction

Natural Gas Vehicle Filter product is designed to protect critical engine components in compressed natural gas Vehicles(NGV). Contaminants can be introduced into the vehicle's fuel tank when being fueled. Contaminants may come from CNG compressors and storage facilities. These unit is specifically designed to remove oil, water and solid contamination from compressed natural gas. The Hy-Lok's filter remove over 95% of all aerosols in the 0.3 to 0.6 micron range.

Features

- Hy-Lok's filter is designed to use with CNG systems.
- Durable construction and simple servicing.
- Small size allows for installation versatility.
- Removes over 95% of all aerosols in the 0.3 to 0.6 micron range
- Easy to change filter element.
- Maximum burst pressure of 16000psig.

Technical Data

- Maximum Operating Pressure : 3600 psig (250 bar) @ 100°F (38°C)
- Operating Temperature Range : From -40°F to 250°F (-40°C to 121°C)
- Rated Flow : 30 SCFM @ 100psig
- Pressure Drop : 0.5 to 1psig

Dimensions and Note

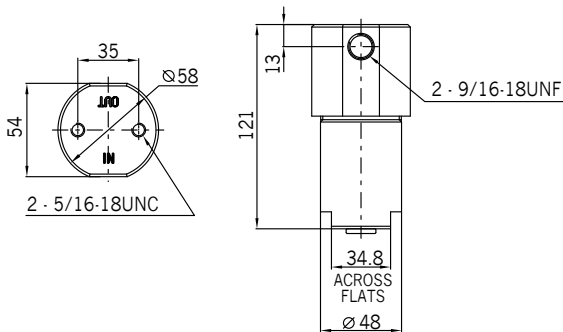

Installation Note

The unit should be located in an accessible and protected location for easy servicing. Maintain at least 3" (76mm) of clearance below the unit for element access. The drain port must face down.

Service Note

The unit must not be under pressure during serving. Injury to personnel may result. Close the shut-off valve shown in the illustration above and slowly relieve line pressure before attempting service.

Replacing the Element

Change the element at the same time as engine oil filter changes or at least every 5000km.

Draining the Housing

Drain the housing every 2500km or as necessary. With line pressure relieved, remove the drain plug using a wrench, then cleaning the plug.

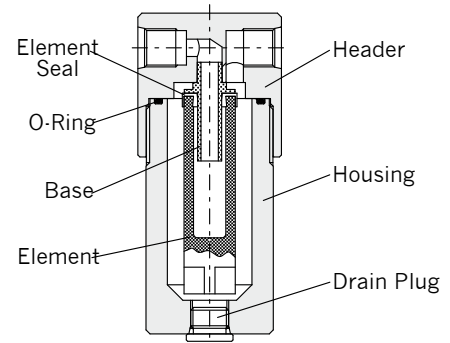

Material of Construction

Description	Material / ASTM Specification
Header	Anodized Aluminium 6061
Housing	Anodized Aluminium 6061
Seal (O-Ring)	NBR
Filter Element	Polyethylene (Gade 10)
Drain Plug	Stainless Steel 316
Base	Nylon

Installation Diagram

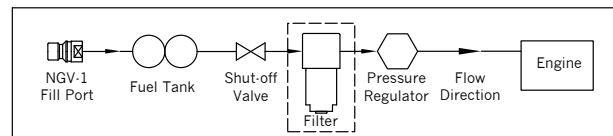

Purge Valve

Introduction

Hy-Lok Purge valves are for bleed, vent or drain purpose manually. The knurled cap is not separable from the valve body for safety purpose. 1/4 turns of wrench pull-up from finger tight give leak-free closure on first make-up. See our Purge Valves (H-100BPV) for more information (working pressure, ordering information, Dimensions, etc).

Features

- Pressure rating up to 4000psig(275bar)
- Vent hole is bleeds excessive liquid or gas from system lines.
- Knurled cap is crimped to valve body for prevents accidental remove from body.
- Size range from 1/8" thru 1/2" tubing and piping system.

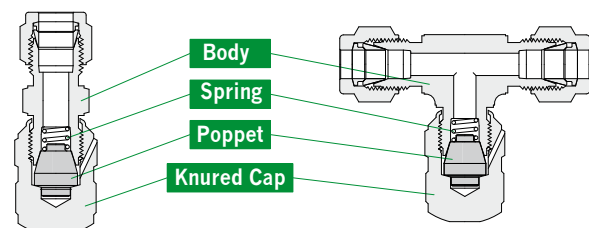

Micron Tee Filter

Features

- Replacement of filter elements with body in line.
- Compact and robust integral union bonnet design.
- Filter elements are made of sintered stainless steel.
- Tested and certified this application per ECE R110.

Technical Data

- Maximum Operating Pressure : 6000 psig (414 bar) @ 100°F (38°C)
- Operating Temperature Range : From -40°F to 250°F (-40°C to 121°C)

Material of Construction

Description	Material / ASTM Specification
Body	SS316 / A479
Sintered Element	Stainless Steel
Seal (O-Ring)	Viton
Element Seal	PTFE

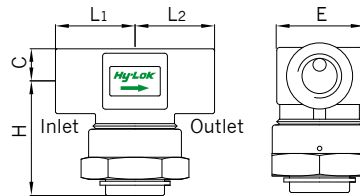

Table of Dimensions

Basic Part Number			Orifice in. (mm)	End Connections		Dimensions (mm)				
				Inlet & Outlet	L ₁	L ₂	H	C	E	
FT	H	-4T	4,4	1/4" Hy-Lok	33,0	33,0	38,8	11,0	28,5	
	H	-6T		3/8" Hy-Lok	36,2	36,2				
	H	-8T		1/2" Hy-Lok	38,7	38,7				
	H	-8M		8mm Hy-Lok	38,7	38,7				
	H	-12M		12mm Hy-Lok	38,7	38,7				
	H	-16M		16mm Hy-Lok	38,7	38,7				

* Dimensions shown with Hy-Lok nuts in finger-tight position, where applicable.

Ordering Information

FT

Filter Type Designator

H

End Connection Designator

- H : Hy-Lok Tube Fitting
- F : Female Thread
- M : Male Thread

4T

Size Designator

Tube O.D. Designation

Tube O.D.	1/4"	3/8"	1/2"	6mm	8mm	10mm	12mm
Designation	4T	6T	8T	6M	8M	10M	12M

50

Filter Element Designator

- 1 : 1 Micron
- 10 : 10 Micron
- 50 : 50 Micron
- 100 : 100 Micron
- 150 : 150 Micron

S316

Body Material Designator

- S316 : 316 Stainless Steel

Tube Fitting







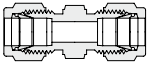
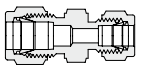
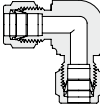
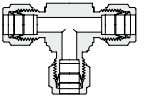
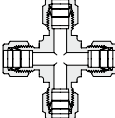

Introduction

Hy-Lok's Tube Fittings are designed for excellent gas-tight sealing and vibration fatigue resistance.

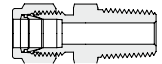
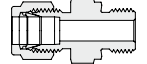
Tested and certified for this application per ECE R110 (for NGV application).

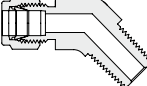
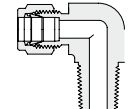
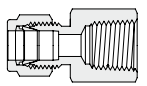
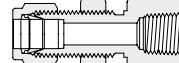
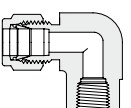
See our Tube Fitting Cataloge (H-200TF) for more information(working pressure, ordering information, Dimensions, Size, etc).

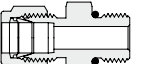
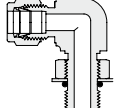
Tube fitting type

Union CUA 	Reducing Union CUR 	Union Elbow CLA 	Union Tee CTA 
Union Cross CXA 	Bulkhead Union CBU 	Male Connector CMC 	Male Connector for Metal Gasket Seal COM 
Bulkhead Male Connector CBMC 	45° Male Elbow CLMB 	Male Elbow CLMA 	Female Connector CFC 
Bulkhead Female Connector CBFC 	Female Elbow CLF 	Reducer CR 	Bulkhead Reducer CBR 
SAE/MS Male Connector CSC 	SAE/MS Male Elbow CSLA 	O-Seal Straight Thread Connector COS 	Male Pipe Weld Connector CWC 